

平成22年度発注者支援業務等に関する説明会

第1部 10:30~11:30

第2部 13:30~14:30

[日時] 平成21年12月22日(火)

[場所] さいたま新都心合同庁舎2号館
5階 共用大研修室5A



関東地方整備局

<資料構成>

- 1. 平成22年度発注者支援業務等の概要**
- 2. 平成22年度発注者支援業務等の契約方式等について**
- 3. 発注者支援業務等（業務別タイプ一覧表）**
- 4. 平成22年度発注者支援業務等の発注の変更ポイント（まとめ）**

この資料は、関東地方整備局ホームページ
(<http://www.ktr.mlit.go.jp/>)に掲載します。
場合によっては、内容の変更があります。

関東地方整備局 H21.12.22

1. 平成22年度発注者支援業務等の概要

2. 平成22年度発注者支援業務等の契約方式等について

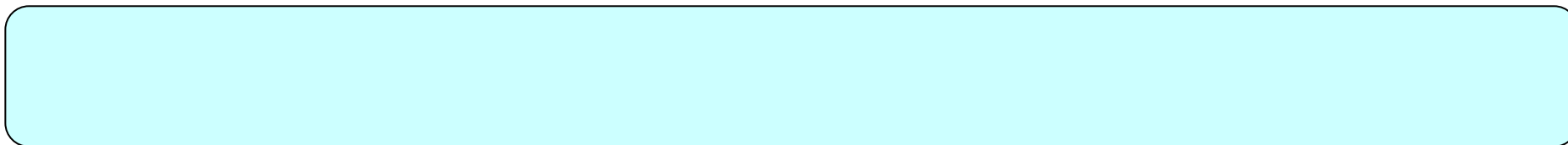

21

20

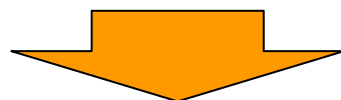

22



20

3



3



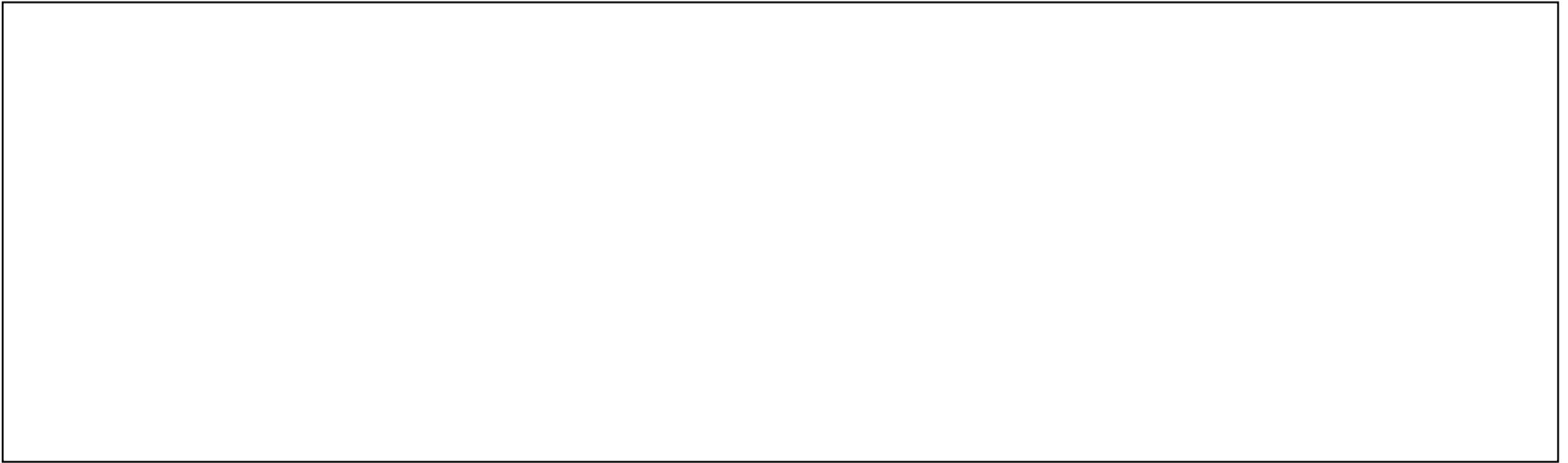





11	12
<hr style="border-top: 1px dashed black;"/>	
25	— <hr style="border-top: 1px solid red;"/> <hr style="border-top: 1px solid red;"/> 25



11	12
25	25



11 —	12
25	— — 25 — —



11	12
25	25



11	12
25	25



/ / /

[Redacted]

[Redacted]

11	12
25	25

3. 発注者支援業務等（業務別タイプ一覧表）（1 / 2）

3. 発注者支援業務等（業務別タイプ一覧表）（2 / 2）

			RCCM 25	25	RCCM RCCM	5 3	10 6
						5 3 1	10 6 2
						5 3 1	5 3 1
						10	20
						20	30
						35	-

4. 平成22年度 発注者支援業務等の 発注の変更ポイント (まとめ)

-

-

-

-

発注者支援業務等の業務概要

＜資料構成＞

1. 発注者支援業務
2. 公物管理（河川関係）
3. 公物管理（道路関係）
4. 行政事務補助

この資料は、標準的な業務概要を示したものです。詳しくは、今後入札契約手続きに入る各々の業務における公告文、入札説明書及び特記仕様書によります。

また、この資料はホームページ (<http://www.ktr.mlit.go.jp/>) に掲載します。

1-1. 工事監督支援業務

H21の品質検査業務・工事管理業務を
H22からは工事監督支援業務として統合します。

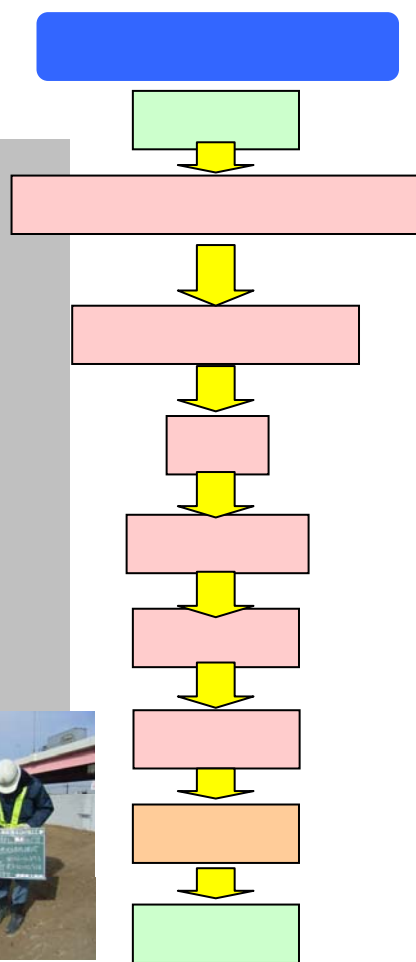
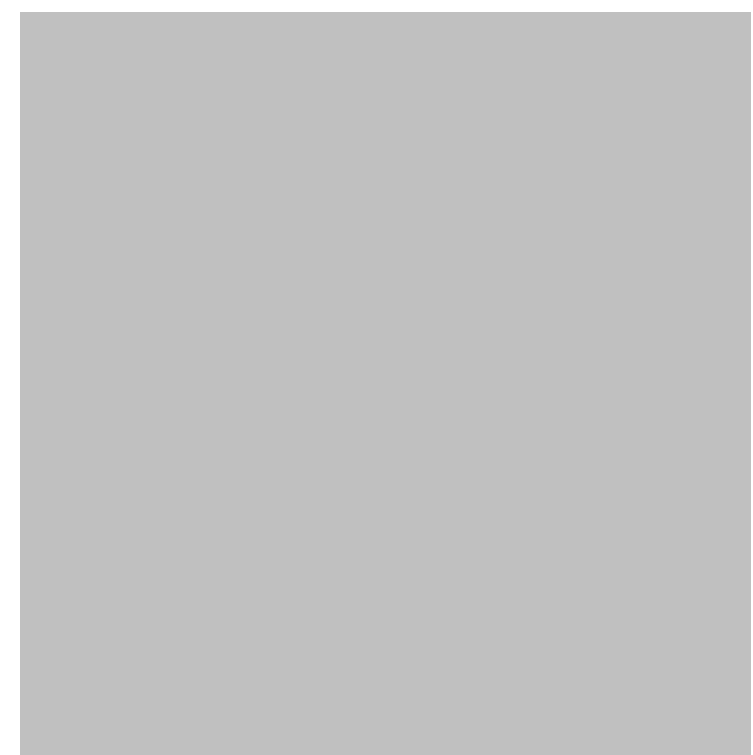
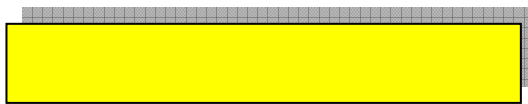
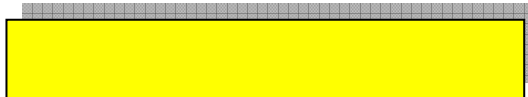

1-2. 技術審査業務

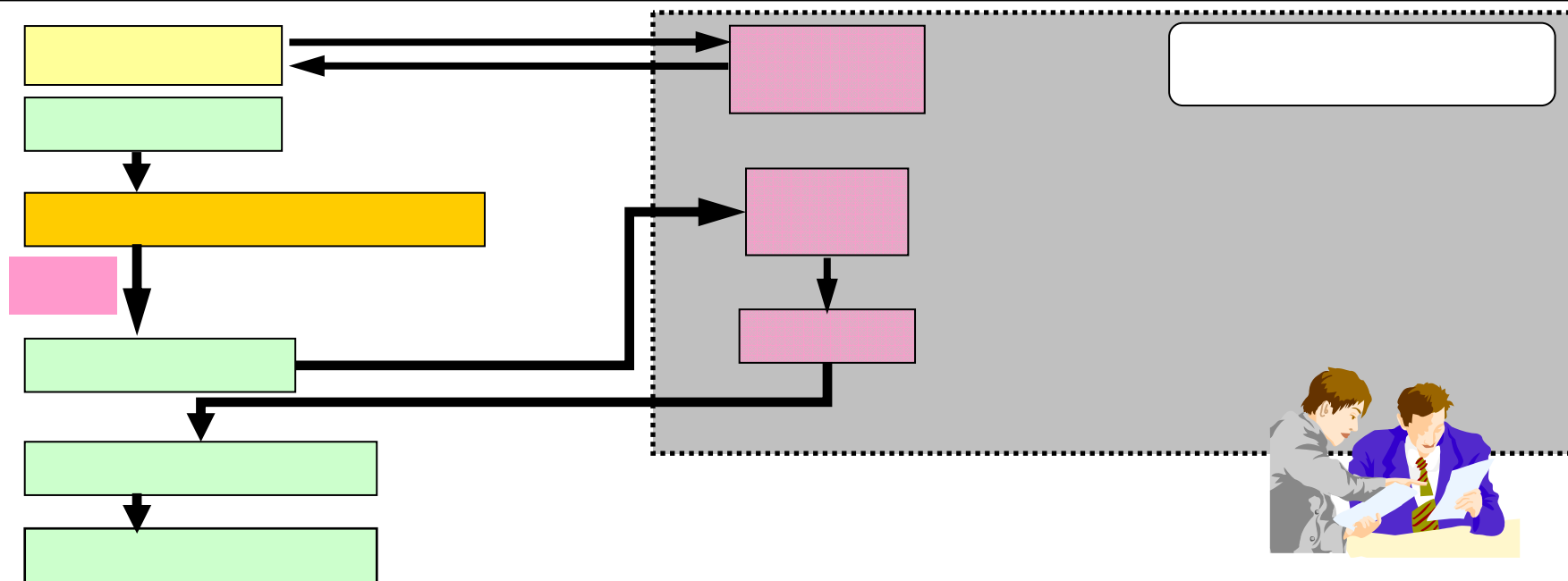
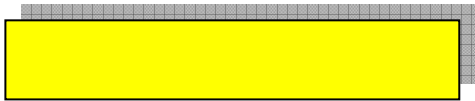

1-3. 積算技術業務

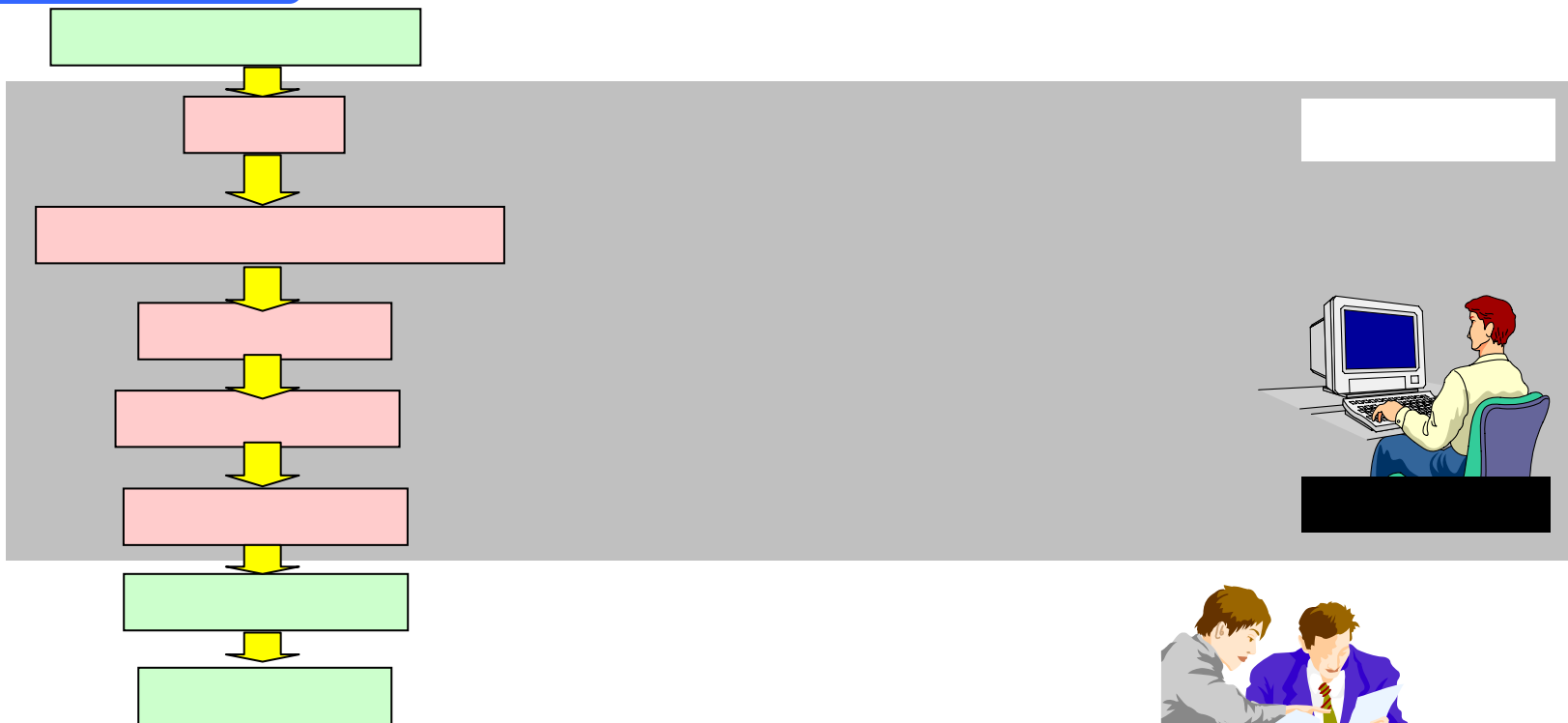
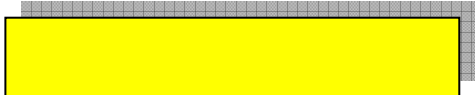

2-1. 公物管理（河川巡視支援業務）

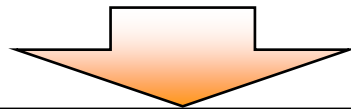
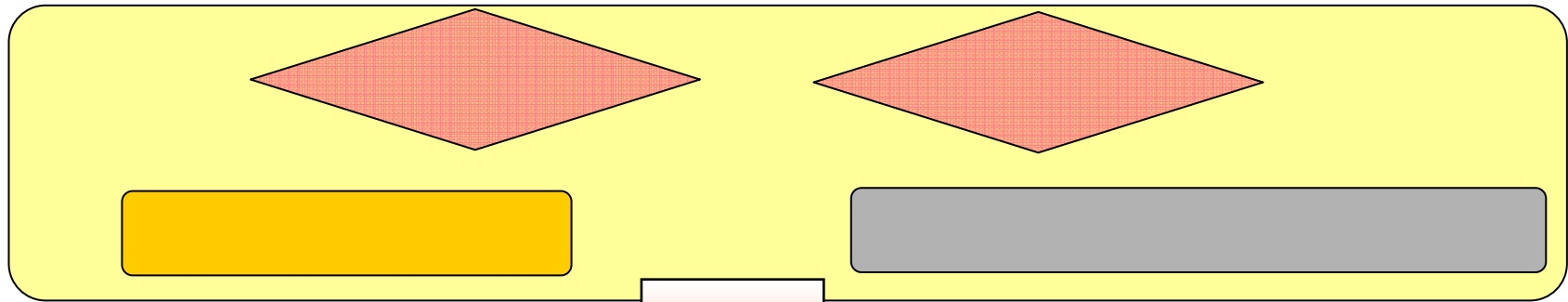

2-1. 公物管理 (河川巡視支援業務)

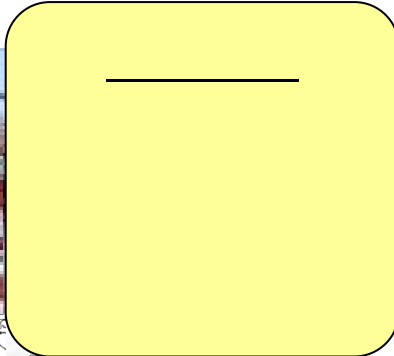
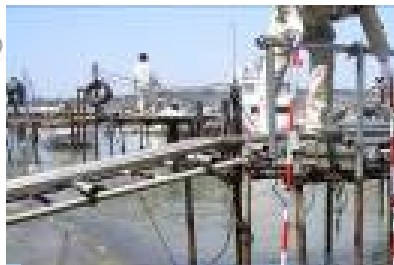
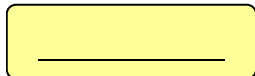
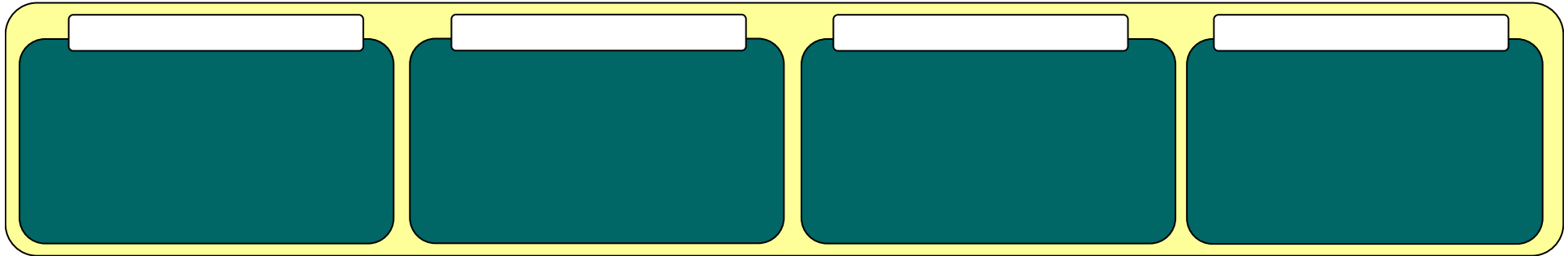

2-2. 公物管理（ダム管理支援業務）

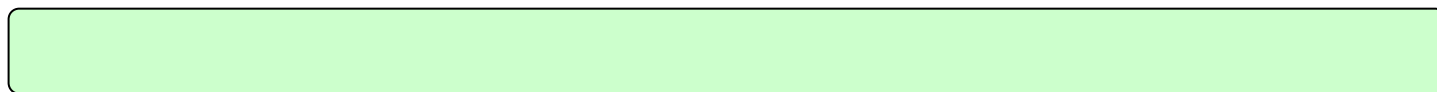
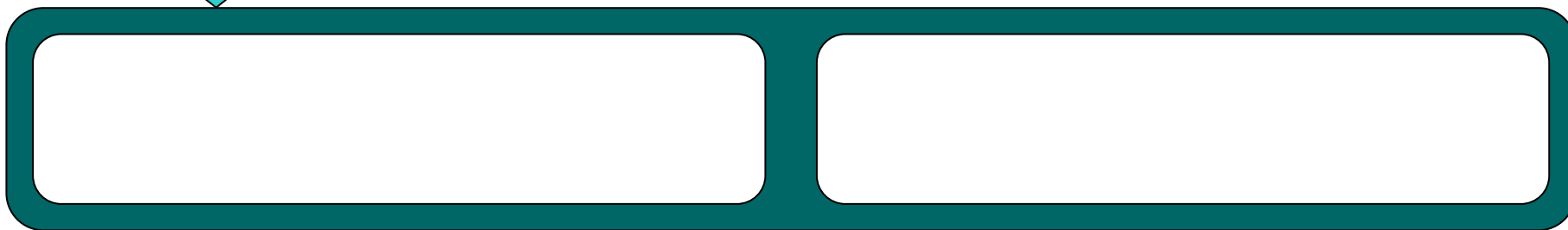

2-2. 公物管理（ダム管理支援業務）

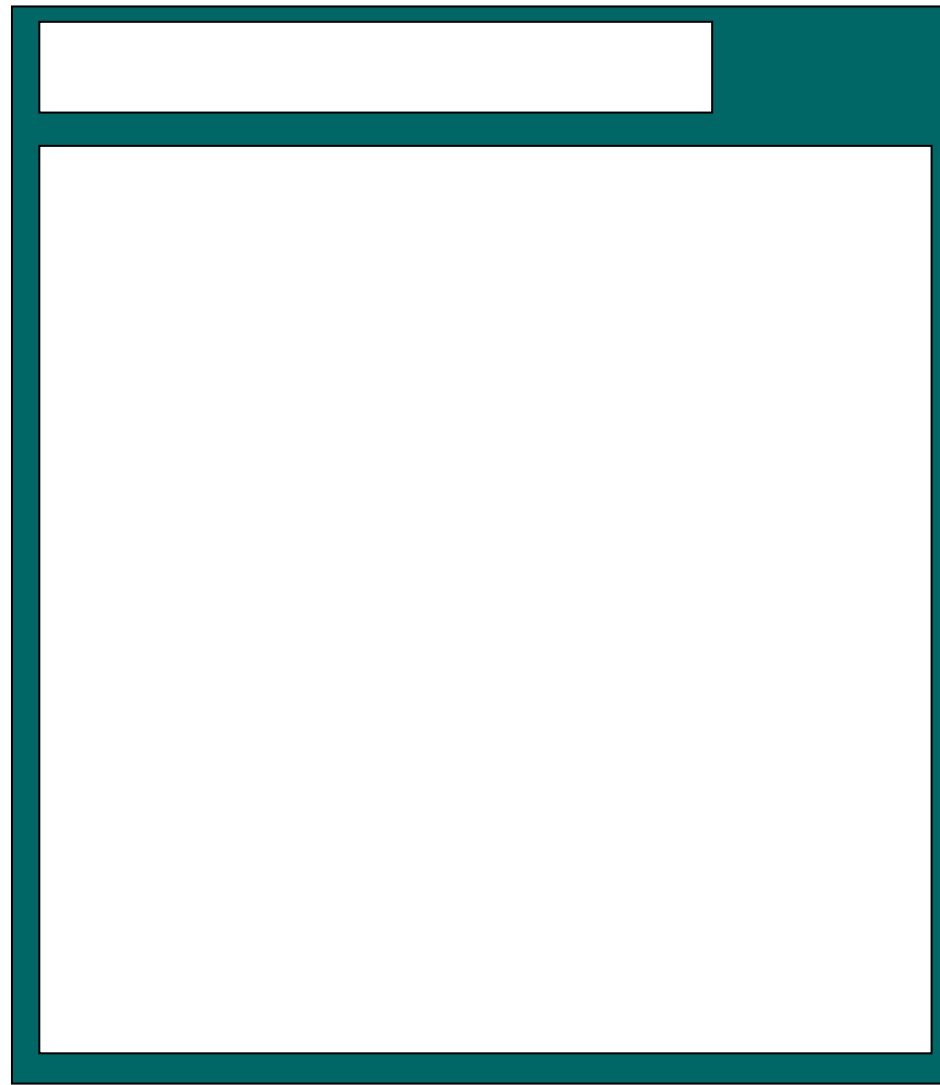
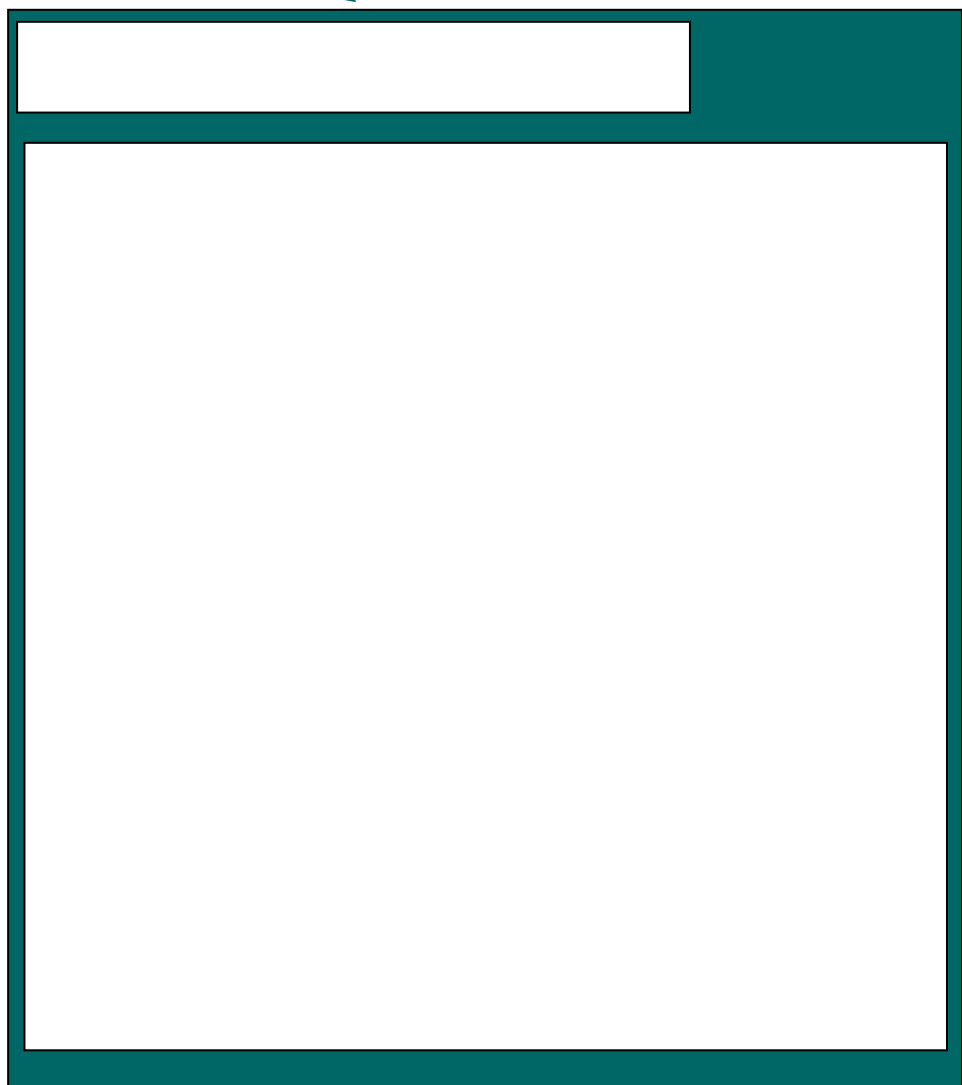

3-1. 公物管理 (道路許認可審査・適正化指導業務)

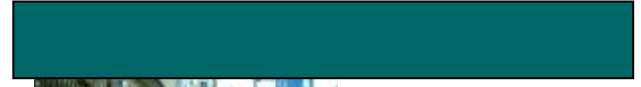
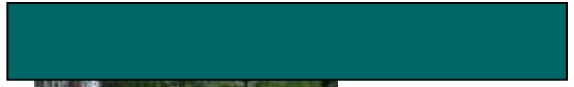
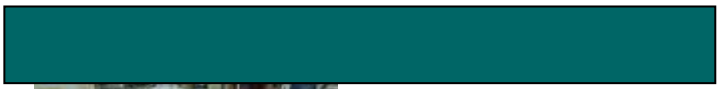

3-1. 公物管理 (道路許認可審査・適正化指導業務)

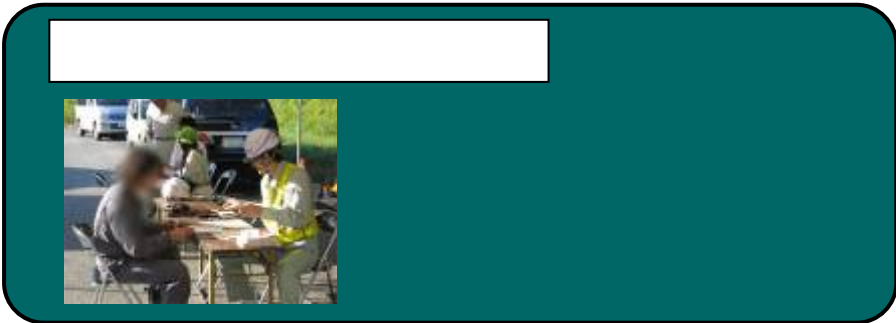
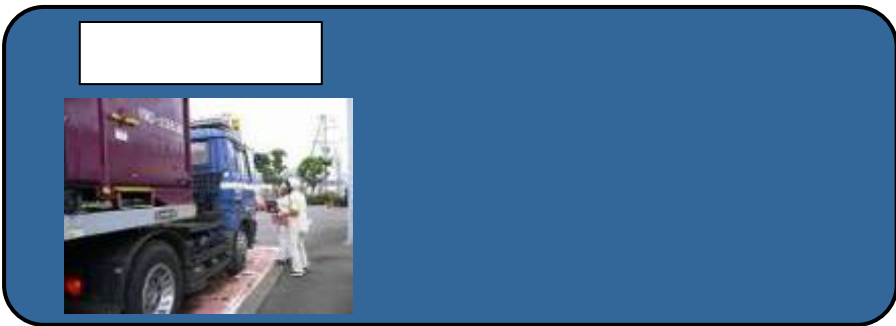
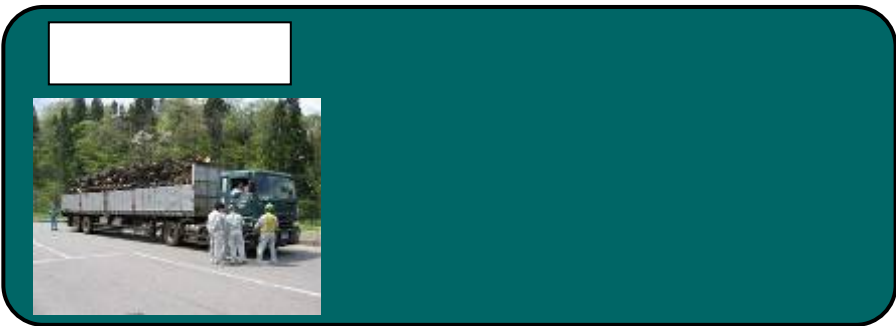
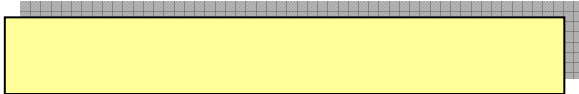

4-1. 行政事務補助 (調査計画資料作成業務)

